

Handling System for Rack Type Basket Cord Conveyor Curve 45°

ITEM # _____

MODEL # _____

NAME # _____

SIS # _____

AIA # _____

863165 (HSBCC45C)

 Cord conveyor for baskets,
 45° curve Unit

Short Form Specification

Item No. _____

Constructed in 304 AISI stainless steel. Square 40x40mm tubular legs on height-adjustable feet. Designed to be connected with rack type dishwasher using 500x500mm baskets.

Main Features

- Cord system generates smooth basket movement and improves hygiene.
- Range built in modules to allow a large number of conveyor combinations.
- Available as optional accessory a remote easy-to-reach emergency-stop buttons fitted where required.
- Conveyor speed is controlled by the dishwasher and the system automatically follows the machine speed.
- "Key holes" and "snap on" system reduces the number of screws needed for fast and easy installation.
- Designed to be connected with rack type dishwasher.
- The unit is part of the complete motorized handling system which can be installed either on loading and/ or unloading sides providing automatic loading and unloading the baskets for better ergonomic operation.

Construction

- All surfaces smooth with polished finish.
- 40x40mm stainless steel tubular and square legs.
- Thick welded flanges for sturdy connection between the units.
- S/S plain conveyor base for easy cleaning.
- Constructed in AISI 304 1,5mm stainless steel.
- 15mm reinforced polyurethane cord, for smooth and easy running.
- Designed for 500x500mm baskets.
- 304 AISI stainless steel construction throughout.
- Included strainer basket to collect the food waste for easy to clean.

Optional Accessories

- 10 m cord for cord conveyor (mandatory - to be ordered according to the length of the complete layout) PNC 863170
- 30 m cord for cord conveyor (mandatory - to be ordered according to the length of the complete layout) PNC 863171
- 50 m cord for cord conveyor (mandatory - to be ordered according to the length of the complete layout) PNC 863172
- Kit for cord welding PNC 865143
- Emergency stop kit for Rack Type Dishwasher (not for Basic handling system) PNC 865162

APPROVAL: _____

Front

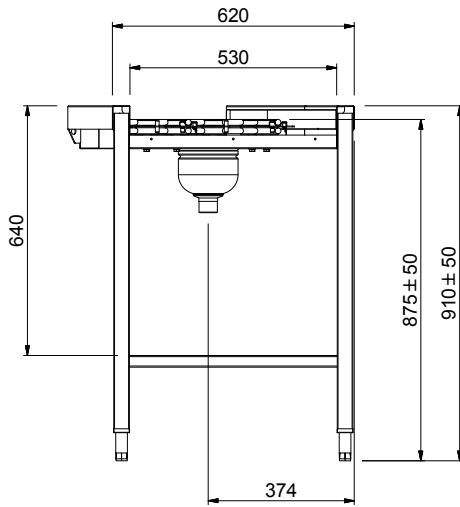

Side

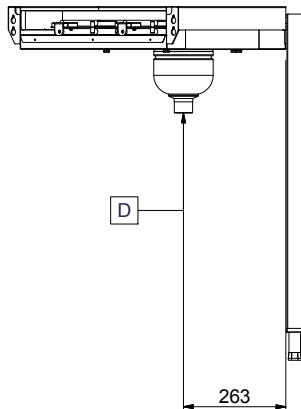

D = Drain

Top

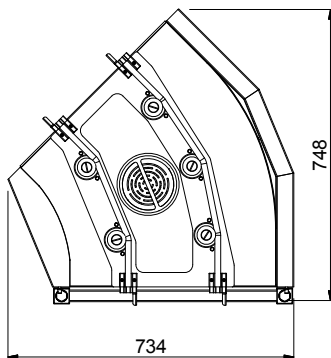
Key Information:
External dimensions, Width:

863165 (HSBCC45C) 600 mm

External dimensions, Depth: 600 mm

External dimensions, Height: 910 mm

Net weight: 14 kg

Basin material:

 Stainless Steel AISI 304 -
 EN 1.4301